

DEHYDRATORS AND FILTERS

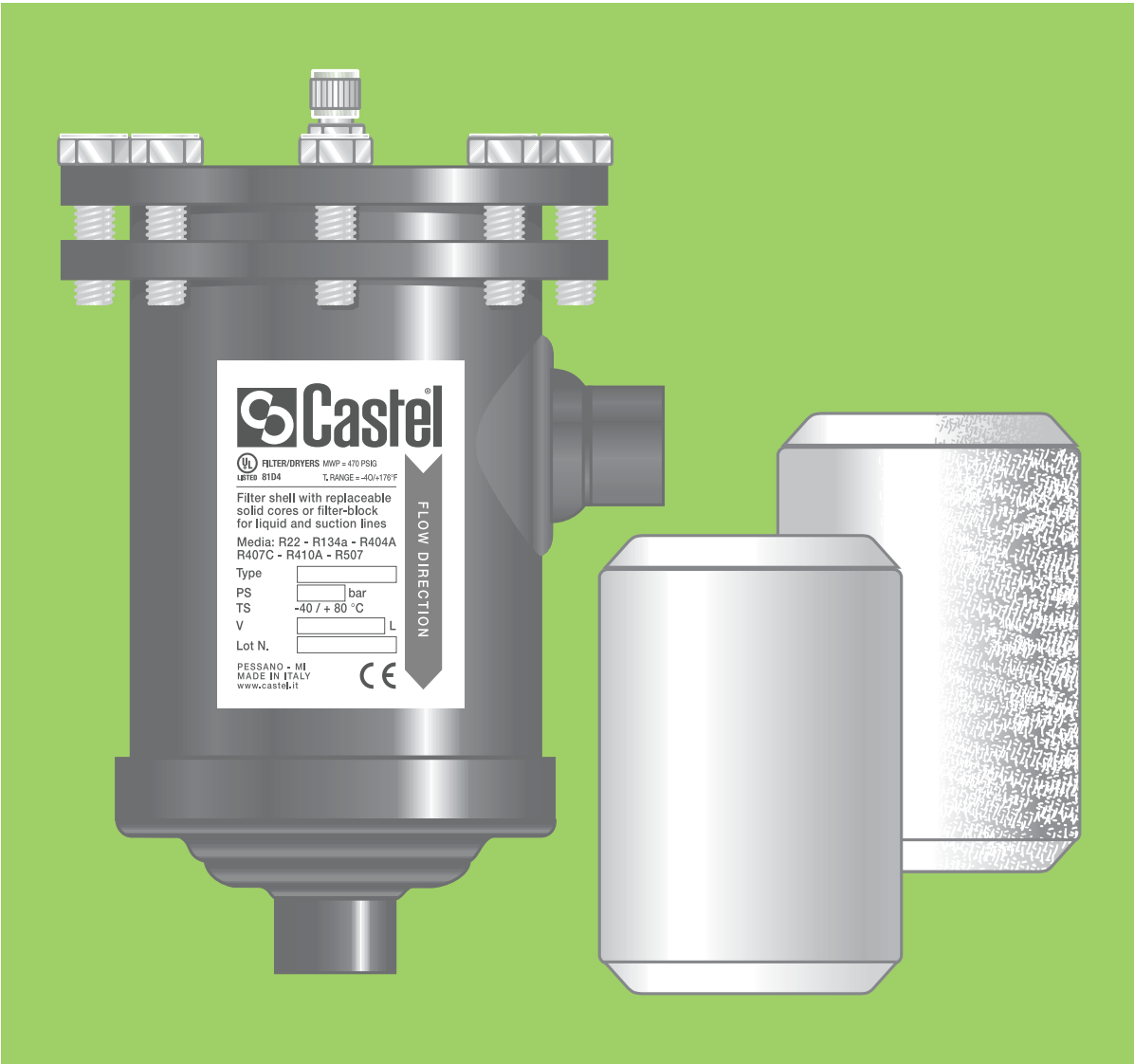



DEHYDRATION OF REFRIGERANTS

Among contaminating agents causing serious damages to refrigerating systems, moisture plays a major role. Its presence, even possible in the refrigerating system, is due to many factors:

- inadequate or insufficiently prolonged vacuum before refrigerant charging;
- oil used for topping up remained exposed to air humidity;
- refrigerant used for subsequent additions contained in non dried vessels;
- sealing defects especially in systems not designed for operation at low temperatures.

High temperatures combined with humidity give rise to complex phenomena enhancing acid formation both in lubricating oil and refrigerant.

Oil organic acids react with metal and favor the formation of sludge, which are viscous clots consisting of insoluble metal salts and large molecules of polymerized oil.

Sludge affects the lubrication of the moving elements of the compressor, can clog valves and filters and cause serious damages.

Acids, especially hydrofluoric acid, produced by the hydrolysis of the fluorinated refrigerant (in compressors iron and aluminum act as catalysts) are particularly corrosive.

Acids etch metal surfaces with the consequent formation of crystal salts, which stick to surfaces and affect the total heat exchange coefficient in the condenser and in the evaporator.

In the sealed and semi-sealed groups, these salts damage the windings of electric motors as in these groups cold gas cools windings through direct contact. On the other hand, water solubility in refrigerants in a liquid phase, is quite reduced, especially at low temperatures.

As a consequence, when in the system water exceeds the very low limits of solubility admitted at low temperature, excess water turns into ice, and blocks expansion valves and capillaries either partially or totally.

Consequently, refrigerating plants must be equipped with a filter drier on the liquid line and types available on the market are essentially two: molecular sieve driers and solid core driers.

In molecular sieve driers, with a charge constituted by non-agglomerated products, the dehydrating mass is pressed in between two fine steel mesh disks, or two filtering disks of various material, kept in place by a spring.

In solid core driers, dehydrating and deacidifying products with binders constitute the block. Water adsorption combines with the neutralization of acids that may be present in the refrigerant, and with a strong filtering action.

Castel have planned either its production lines of hermetic driers on this second solution that avoid any risk of abrasion of the charge and consequently the making of powder and permit to put the filter in any position inside the refrigerating system.

It is always advisable to install a moisture indicator downstream the filter, which will show the refrigerant moisture and, consequently, the degree of efficiency of the filter.

The dehydrating capacity of Castel drier is relative to the charge of refrigerant and not to the refrigeration potential of the plant.

As a matter of fact, for the same refrigerant potential and for the same type of refrigerant fluid, there can be different refrigerant charges according to the type, design and working conditions of the plant as well as to the shutter degree.

The data shown in the following tables are deduced from the test results of the present Castel production.

It is important to note in the case of a high oil level in the circuit (> 5%) the data shown in the tables will be reduced considerably.

ANTI-ACID SOLID CORE FILTER DRIERS WITH MOLECULAR SIEVES AND ACTIVATED ALUMINA – SERIES 42

Approved by Underwriters Laboratories Inc. 

SOLID CORE FILTER DRIERS WITH 100% MOLECULAR SIEVES – SERIES 43

Approved by Underwriters Laboratories Inc. 

APPLICATIONS

The filters, shown in this chapter, are classified “Pressure vessels” in the sense of the Pressure Equipment Directive 94/23/EC, Article 1, Section 2.1.1 and are subject of Article 3, Section 1.1 of the same Directive. They are designed for installation on commercial refrigerating systems and on civil and industrial conditioning plants, which use refrigerant fluids proper to the Group II (as defined in Article 9, Section 2.2 of Directive 97/23/EC and referred to in Directive 67/548/EEC).

Filters series 42 and series 43 have been developed for specific installations on refrigerating systems using HFC refrigerant fluids, particularly R134a, R404A, R407C, R410A ed R507 mixed with polyolester lubricants. In spite of this, the new block may be successfully used also in refrigerating systems using the old CFC or HCFC refrigerant fluids, mixed with mineral lubricants

CONSTRUCTION

The filter is completely manufactured in steel, either with nickel-plated Flare threaded connections. The product range also includes types with copper plated solder connections, offering the possibility to solder the copper pipe inside the connections (ODS) or outside the connections, using a copper sleeve (ODM).

On specific customers' request, Castel is also able the supply them filters series 42 and 43 with:

- solder connections made of copper tube EN 12735-1 – Cu-DHP
- ORFS (O-Ring Face Seal) threaded connections according to SAE J 1453 Standard.

The blocks in the filters series 42 are molded from a blend of dehydrating charge, 80% of 3 Å molecular sieves and 20 % of activated alumina, and a special binding agent in appropriate proportions. The choice of blend, molecular sieves – activated alumina, gives to the block a very high capacity of acid adsorption also maintaining very good dehydrating characteristics. The presence of a controlled and defined percentage of activated alumina, lower than the maximum value recommended by ASERCOM, keeps unchanged the original concentration of additives in the polyolester lubricant.





The blocks in the filters series 43 are molded from a blend of dehydrating charge, totally made of 3 Å molecular sieves, and a special binding agent in appropriate proportions. The choice of the 3 Å molecular sieves, as sole dehydrating material, gives to the block a superlative capacity of water adsorption also maintaining quite good deacidifying characteristics.

The manufacturing process gives a considerable compacted ness and stoutness to both the products so that they are resistant to shocks and abrasions.

The shape of the block is designed in order to offer the maximum possible surface area to the incoming fluid. The internal cavity is also positioned in such a way as to have a uniform wall thickness. As a result, the fluid encounters a constant strength at all points, flows linearly through the block, and ensures efficient dehydration and minimum charge loss.

The block is chemically inert, not deliquescent, does not react with refrigerating fluids, and is capable of blocking oil by-products dragged into the circuit. Impurities accumulate in the ring between the metal shell and the block; this prevents filter clogging.

EXAMPLE OF SELECTION

System data:

Refrigerant: R407C

Condensing temperature: + 50 [°C]

Weight of refrigerant: 34 [kg]

According to DIN 8949:2000, the adsorption capacity of the drier is given by:

$$(1.050 - 50) \times 34 / 1.000 = 34 \text{ g of H}_2\text{O}$$

where:

1.050 ppm. = moisture in the refrigerant entering the filter according to DIN 8949:2000

50 ppm. = moisture in the refrigerant flowing out the filter according to DIN 8949:2000

Comparing the absorption capacity required with the values shown in table 2, drier mod.4032 should be selected, with a water absorption capacity of 47,5 g at 50 °C. If the dehydrating capacity of products is expressed in water drops, it must be remembered that:

$$1\text{g H}_2\text{O} = 20 \text{ water drops}$$

In this case and when a molecular sieve drier is selected, the following result is obtained:

$$34 \times 20 = 680 \text{ water drops.}$$

If moisture exceeds the values specified in DIN 8949:2000, a drier with a higher adsorption capacity shall be selected.

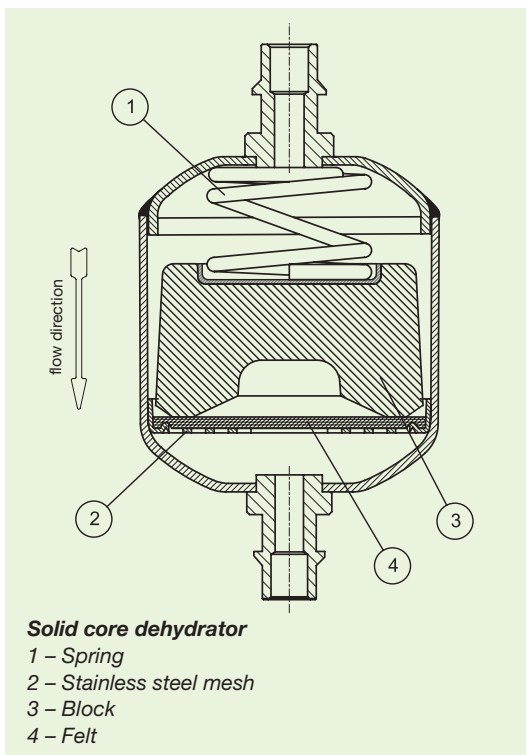

TABLE 1: General Characteristics

Catalogue Number		International Reference	Block Filtering Surface [cm ²]	Nominal Volume [cm ³]	Connections				TS [°C]		PS [bar]	Risk Category according to PED									
High water capacity core (1)					SAE Flare	ODS		ODM		min.			max.								
Threaded Connections	Solder Connections					Ø [in.]	Ø [mm]	Ø [in.]	Ø [mm]												
4303/2	-	032	47	50	1/4"	-	-	-	-40	+80	42	Art. 3.3									
4303/2F (2)	-	-			1/4"	-	-	-													
-	4303/2S	032S			-	1/4"	-	3/8"					-								
4303/3	-	033			3/8"	-	-	-					-								
4305/2	-	052	70	80	1/4"	-	-	-					-40	+80	42	Art. 3.3					
4305/2F (2)	-	-			1/4"	-	-	-									-				
-	4305/2S	052S			-	1/4"	-	3/8"									-				
4305/3	-	053			3/8"	-	-	-									-				
-	4305/3S	053S			-	3/8"	-	1/2"									-				
-	4305/M10S	-			-	-	10	-									12				
4308/2	-	082	103	130	1/4"	-	-	-									-40	+80	42	Art. 3.3	
4308/2F (2)	-	-			1/4"	-	-	-													-
-	4308/2S	082S			-	1/4"	-	3/8"													-
4308/3	-	083			3/8"	-	-	-													-
4308/3F (2)	-	-			3/8"	-	-	-													-
-	4308/3S	083S			-	3/8"	-	1/2"													-
-	4308/M10S	-			-	-	10	-													12
-	4308/M12S	-			-	-	12	-													14
4308/4	-	084			1/2"	-	-	-													-
-	4308/4S	084S			-	1/2"	-	5/8"													16
4316/2	-	162	155	250	1/4"	-	-	-	-40	+80	42	Art. 3.3									
4316/3	-	163			3/8"	-	-	-													-
4316/3F (2)	-	-			3/8"	-	-	-													-
-	4316/3S	163S			-	3/8"	-	1/2"													-
-	4316/M10S	-			-	-	10	-					12								
-	4316/M12S	-			-	-	12	-					14								
4316/4	-	164			1/2"	-	-	-					-								
-	4316/4S	164S			-	1/2"	-	5/8"					16								
4316/5	-	165			5/8"	-	-	-					-								
-	4316/5S	165S			-	5/8"	16	3/4"					-								
4330/3	-	303	310	500	3/8"	-	-	-					-40	+80	42	Art. 3.3					
-	4330/3S	303S			-	3/8"	-	1/2"									-				
4330/4	-	304			1/2"	-	-	-									-				
-	4330/4S	304S			-	1/2"	-	5/8"									16				
4330/5	-	305			5/8"	-	-	-									-				
-	4330/5S	305S			-	5/8"	16	3/4"									-				
4332/4	-	304	255	500	1/2"	-	-	-									-40	+80	42	Art. 3.3	
-	4332/4S	304S			-	1/2"	-	5/8"													16
4332/5	-	305			5/8"	-	-	-													-
-	4332/5S	305S			-	5/8"	16	3/4"													-
4341/5	-	415	330	670	5/8"	-	-	-	-40	+80	42	Art. 3.3									
-	4341/5S	415S			-	5/8"	16	3/4"													-
4341/6	-	416			3/4"	-	-	-													-
-	4341/6S	416S			-	3/4"	-	7/8"													-
-	4341/7S	417S			-	7/8"	-	1.1/8"													-
-	4375/4S	754S			660	1340	-	1/2"													-
-	4375/5S	755S	-	5/8"			16	3/4"													-
-	4375/6S	756S	-	3/4"			-	7/8"													-
-	4375/7S	757S	-	7/8"			-	1.1/8"													-
-	4375/9S	759S	-	1.1/8"			-	1.3/8"													35

(1) 100% molecular sieves; (2) Male-female connections (Inlet female)
(3) PS = 400 psig in compliance with the UL approval



TABLE 2: General Characteristics

Catalogue Number		International Reference	Block Filtering Surface [cm ²]	Nominal Volume [cm ³]	Connections				TS [°C]		PS [bar]	Risk Category according to PED	
Anti-acid core (1)					SAE Flare	ODS		ODM		min.			max.
Threaded Connections	Solder Connections					Ø [in.]	Ø [mm]	Ø [in.]	Ø [mm]				
4203/2	-	032	47	50	1/4"	-	-	-	-40	+80	42 (2)	Art. 3.3	
-	4203/2S	032S			-	1/4"	-	3/8"					-
4203/3	-	033			3/8"	-	-	-					-
4205/2	-	052	70	80	1/4"	-	-	-					
-	4205/2S	052S			-	1/4"	-	3/8"					-
4205/3	-	053			3/8"	-	-	-					-
-	4205/3S	053S	-	3/8"	-	1/2"	-						
4208/2	-	082	103	130	1/4"	-	-	-					
-	4208/2S	082S			-	1/4"	-	3/8"					-
4208/3	-	083			3/8"	-	-	-					-
-	4208/3S	083S			-	3/8"	-	1/2"					-
4208/4	-	084			1/2"	-	-	-					-
-	4208/4S	084S	-	1/2"	-	5/8"	16						
4216/2	-	162	155	250	1/4"	-	-	-					
4216/3	-	163			3/8"	-	-	-					-
-	4216/3S	163S			-	3/8"	-	1/2"					-
4216/4	-	164			1/2"	-	-	-					-
-	4216/4S	164S			-	1/2"	-	5/8"					16
4216/5	-	165			5/8"	-	-	-					-
-	4216/5S	165S	-	5/8"	16	3/4"	-						
4230/3	-	303	310	500	3/8"	-	-	-					
-	4230/3S	303S			-	3/8"	-	1/2"					-
4230/4	-	304			1/2"	-	-	-					-
-	4230/4S	304S			-	1/2"	-	5/8"					16
4230/5	-	305			5/8"	-	-	-					-
-	4230/5S	305S			-	5/8"	16	3/4"					-
4232/4	-	304	255	500	1/2"	-	-	-					
-	4232/4S	304S			-	1/2"	-	5/8"					16
4232/5	-	305			5/8"	-	-	-					-
-	4232/5S	305S	-	5/8"	16	3/4"	-						
4241/5	-	415	330	670	5/8"	-	-	-					
-	4241/5S	415S			-	5/8"	16	3/4"	-				
4241/6	-	416			3/4"	-	-	-	-				
-	4241/6S	416S			-	3/4"	-	7/8"	-				
-	4241/7S	417S	-	7/8"	-	1.1/8"	-						
-	4275/4S	754S	660	1340	-	1/2"	-	5/8"	16				
-	4275/5S	755S			-	5/8"	16	3/4"	-				
-	4275/6S	756S			-	3/4"	-	7/8"	-				
-	4275/7S	757S			-	7/8"	-	1.1/8"	-				
-	4275/9S	759S			-	1.1/8"	-	1.3/8"	35				

(1) 80% molecular sieves + 20% activated alumina
 (2) PS = 400 psig in compliance with the UL approval

TABLE 3: Refrigerant Flow Capacity and Water Capacity

Catalogue Number	Refrigerant Flow Capacity, pressure drop 0,07 bar (1) [kW]					Water Capacity at + 25 °C (2) [g H ₂ O]					Dehydratable Charge at + 25 °C [kg refrigerant]					Water Capacity at + 50 °C (2) [g H ₂ O]					Dehydratable Charge at + 50 °C [kg refrigerant]				
	R134a	R22	R404A R507	R407C	R410A	R134a	R22	R404A R507	R407C	R410A	R134a	R22	R404A R507	R407C	R410A	R134a	R22	R404A R507	R407C	R410A	R134a	R22	R404A R507	R407C	R410A
4303/2	6,5	7,0	4,6	6,9	7,0																				
4303/2F						4,1	3,8	4,2	3,4	3,7	4,4	4,0	4,5	3,6	3,9	3,5	3,0	3,9	2,7	2,9	3,8	3,2	4,2	2,9	3,2
4303/2S	8,0	8,6	5,6	8,5	8,6																				
4303/3	14,9	16,1	10,5	16,0	16,2																				
4305/2	6,7	7,2	4,7	7,1	7,2																				
4305/2F																									
4305/2S	8,2	8,9	5,8	8,8	9,0																				
4305/3	15,4	16,6	10,8	16,5	16,7	7,3	6,7	7,4	6,0	6,5	7,8	7,2	8,0	6,4	7,0	6,3	5,3	6,9	4,8	5,2	6,8	5,7	7,4	5,2	5,6
4305/3S	19,4	21,0	13,7	20,8	21,2																				
4305/M10S																									
4308/2	6,9	7,5	4,9	7,4	7,5																				
4308/2F																									
4308/2S	8,5	9,2	6,0	9,1	9,3																				
4308/3	18,0	19,5	12,7	19,3	19,6																				
4308/3F																									
4308/3S	22,8	24,7	16,1	24,5	24,8	12,7	11,6	13,0	10,4	11,3	13,7	12,5	13,9	11,2	12,2	10,9	9,3	12,0	8,4	9,1	11,8	10,0	13,0	9,0	9,8
4308/M10S																									
4308/M12S	29,0	31,3	20,4	31,0	31,4																				
4308/4	24,0	25,9	16,9	25,7	26,0																				
4308/4S	29,0	31,3	20,4	31,0	31,4																				
4316/2	6,9	7,5	4,9	7,4	7,5																				
4316/3	19,7	21,3	13,9	21,1	21,4																				
4316/3F																									
4316/3S	24,6	26,6	17,3	26,4	26,7																				
4316/M10S						25,1	22,9	25,6	20,5	22,3	27,0	24,6	27,5	22,0	24,0	21,6	18,4	23,8	16,5	18,0	23,2	19,8	25,6	17,7	19,4
4316/M12S	34,1	36,9	24,0	36,6	37,0																				
4316/4	28,2	30,5	19,9	30,3	30,6																				
4316/4S	34,1	36,9	24,0	36,6	37,0																				
4316/5	37,6	40,6	26,4	40,3	40,8																				
4316/5S	45,0	48,7	31,7	48,3	48,9																				
4330/3	21,7	23,4	15,3	23,2	23,5																				
4330/3S	27,1	29,3	19,0	29,0	29,4																				
4330/4	30,9	33,4	21,8	33,2	33,5																				
4330/4S	37,3	40,4	26,3	40,0	40,5	50,2	45,8	51,2	41,0	44,6	54,0	49,2	55,1	44,1	48,0	43,2	36,8	47,6	33,0	36,0	46,5	39,6	51,2	35,5	38,7
4330/5	38,8	41,9	27,3	41,6	41,9																				
4330/5S	46,6	50,4	32,8	50,0	50,6																				
4332/4	33,6	36,3	23,6	36,0	36,4																				
4332/4S	40,5	43,8	28,5	43,4	44,0																				
4332/5	39,9	43,1	28,1	42,8	43,0	45,4	41,4	46,4	37,2	40,5	48,8	44,5	49,9	40,0	43,5	39,1	33,2	43,1	29,9	32,6	42,0	35,7	46,3	32,2	35,1
4332/5S	48,2	52,1	33,9	51,7	52,3																				
4341/5	40,9	44,2	28,8	43,8	44,4																				
4341/5S	49,5	53,5	34,8	53,1	53,7																				
4341/6	67,2	72,6	47,3	72,0	73,0	61,4	56,1	62,8	50,3	54,7	66,0	60,3	67,5	54,1	58,8	53,0	45,0	58,3	40,5	44,1	57,0	48,4	62,7	43,5	47,4
4341/6S																									
4341/7S	74,2	80,2	52,2	79,6	80,5																				
4375/4S	53,4	57,7	37,5	57,3	57,9																				
4375/5S	54,5	58,9	38,3	58,4	59,1																				
4375/6S	80,6	87,1	56,8	86,4	87,6	122,8	112,2	125,6	100,6	109,4	132,0	120,6	135,1	108,2	117,6	106,0	90,0	116,6	81,0	88,2	114,0	96,8	125,4	87,1	94,8
4375/7S	92,8	100,3	65,3	99,5	100,6																				
4375/9S	96,5	104,3	67,9	103,5	104,7																				

(1) (2) See caption on page 98.

TABLE 4: Refrigerant Flow Capacity and Water Capacity

Catalogue Number	Refrigerant Flow Capacity, pressure drop 0,07 bar (1) [kW]					Water Capacity at +25 °C (2) [g H ₂ O]					Dehydratable Charge at +25 °C [kg refrigerant]					Water Capacity at +50 °C (2) [g H ₂ O]					Dehydratable Charge at +50 °C [kg refrigerant]				
	R134a	R22	R404A R507	R407C	R410A	R134a	R22	R404A R507	R407C	R410A	R134a	R22	R404A R507	R407C	R410A	R134a	R22	R404A R507	R407C	R410A	R134a	R22	R404A R507	R407C	R410A
4203/2	6,5	7,0	4,6	6,9	7,0																				
4203/2S	8,0	8,6	5,6	8,5	8,6	3,5	3,2	3,6	2,9	3,1	3,8	3,4	3,9	3,1	3,4	3,0	2,6	3,3	2,3	2,5	3,3	2,8	3,6	2,5	2,7
4203/3	14,9	16,1	10,5	16,0	16,2																				
4205/2	6,7	7,2	4,7	7,1	7,2																				
4205/2S	8,2	8,9	5,8	8,8	9,0	6,2	5,7	6,3	5,1	5,5	6,7	6,1	6,8	5,5	6,0	5,4	4,5	5,9	4,1	4,5	5,8	4,9	6,3	4,4	4,8
4205/3	15,4	16,6	10,8	16,5	16,7																				
4205/3S	19,4	21,0	13,7	20,8	21,2																				
4208/2	6,9	7,5	4,9	7,4	7,5																				
4208/2S	8,5	9,2	6,0	9,1	9,3																				
4208/3	18,0	19,5	12,7	19,3	19,6	10,8	9,9	11,0	8,8	9,6	11,6	10,6	11,9	9,5	10,3	9,3	7,9	10,2	7,1	7,7	10,0	8,5	11,0	7,7	8,3
4208/3S	22,8	24,7	16,1	24,5	24,8																				
4208/4	24,0	25,9	16,9	25,7	26,0																				
4208/4S	29,0	31,3	20,4	31,0	31,4																				
4216/2	6,9	7,5	4,9	7,4	7,5																				
4216/3	19,7	21,3	13,9	21,1	21,4																				
4216/3S	24,6	26,6	17,3	26,4	26,7																				
4216/4	28,2	30,5	19,9	30,3	30,6	21,3	19,5	21,8	17,4	19,0	22,9	20,9	23,4	18,7	20,4	18,4	15,6	20,2	14,0	15,3	19,7	16,8	21,8	15,1	16,5
4216/4S	34,1	36,9	24,0	36,6	37,0																				
4216/5	37,6	40,6	26,4	40,3	40,8																				
4216/5S	45,0	48,7	31,7	48,3	48,9																				
4230/3	21,7	23,4	15,3	23,2	23,5																				
4230/3S	27,1	29,3	19,0	29,0	29,4																				
4230/4	30,9	33,4	21,8	33,2	33,5	42,7	38,9	43,5	34,9	37,9	45,9	41,9	46,8	37,5	40,8	36,7	31,3	40,5	28,1	30,6	39,5	33,6	43,5	30,2	32,9
4230/4S	37,3	40,4	26,3	40,0	40,5																				
4230/5	38,8	41,9	27,3	41,6	41,9																				
4230/5S	46,6	50,4	32,8	50,0	50,6																				
4232/4	33,6	36,3	23,6	36,0	36,4																				
4232/4S	40,5	43,8	28,5	43,4	44,0	38,6	35,2	39,4	31,6	34,4	41,5	37,8	42,4	34,0	37,0	33,2	28,2	36,6	25,4	27,7	35,7	30,3	39,4	27,3	29,8
4232/5	39,9	43,1	28,1	42,8	43,0																				
4232/5S	48,2	52,1	33,9	51,7	52,3																				
4241/5	40,9	44,2	28,8	43,8	44,4																				
4241/5S	49,5	53,5	34,8	53,1	53,7																				
4241/6	67,2	72,6	47,3	72,0	73,0	52,2	47,7	53,4	42,8	46,5	56,1	51,3	57,4	46,0	50,0	45,1	38,3	49,6	34,4	37,5	48,4	41,1	53,3	37,0	40,3
4241/6S																									
4241/7S	74,2	80,2	52,2	79,6	80,5																				
4275/4S	53,4	57,7	37,5	57,3	57,9																				
4275/5S	54,5	58,9	38,3	58,4	59,1																				
4275/6S	80,6	87,1	56,8	86,4	87,6	104,4	95,4	106,8	85,5	93,0	112,2	102,5	114,8	91,9	100,0	90,1	76,5	99,1	68,9	75,0	96,9	82,3	106,6	74,0	80,6
4275/7S	92,8	100,3	65,3	99,5	100,6																				
4275/9S	96,5	104,3	67,9	103,5	104,7																				

(1) Maximum values of the refrigerant flow capacity at which the drier can be used when fluid dehydration is not the a major problem, provided that the original moisture is limited before the installation of the drier. The maximum refrigerant flow capacities are referred to a total pressure drop of 0,07 bar, inlet and outlet connections included, (according to ARI STANDARD 710:86 - with condensing temperature at +30 °C and evaporating temperature at -15 °C)

(2) Water capacity values with R22 are referred to the following conditions, fixed in ARI STANDARD 710:86:

- Liquid temperatures: 25 °C and 50 °C
- Equilibrium point dryness, EPD: 60 ppm

Water capacity values with the other refrigerant fluids are referred to the following conditions, fixed in DIN 8949:2000 Standard:

- Liquid temperatures: 25 °C and 50 °C
- Equilibrium point dryness, EPD: 50 ppm

TABLE 5: Dimensions and Weights

Catalogue Number		Connections			Dimensions [mm]		Weight [g]
		SAE Flare	ODS		Ø D	L	
			Ø [in.]	Ø [mm]			
4303/2	4203/2	1/4"	-	-	52	103	240
4303/2F	-	1/4"	-	-		92	230
4303/2S	4203/2S	-	1/4"	-		94	220
4303/3	4203/3	3/8"	-	-		111	235
4305/2	4205/2	1/4"	-	-		119	275
4305/2F	-	1/4"	-	-		109	260
4305/2S	4205/2S	-	1/4"	-		110	260
4305/3	4205/3	3/8"	-	-		127	295
4305/3S	4205/3S	-	3/8"	-		112	260
4305/M10S	-	-	-	10		146	380
4308/2	4208/2	1/4"	-	-		135	345
4308/2F	-	1/4"	-	-		137	345
4308/2S	4208/2S	-	1/4"	-		154	395
4308/3	4208/3	3/8"	-	-		142	380
4308/3F	-	3/8"	-	-		139	345
4308/3S	4208/3S	-	3/8"	-		146	380
4308/M10S	-	-	-	10		162	430
4308/M12S	-	-	-	12		146	380
4308/4	4208/4	1/2"	-	-		158	635
4308/4S	4208/4S	-	1/2"	-		166	690
4316/2	4216/2	1/4"	-	-	154	680	
4316/3	4216/3	3/8"	-	-	151	620	
4316/3F	-	3/8"	-	-	151	630	
4316/3S	4216/3S	-	3/8"	-	158	640	
4316/M10S	-	-	-	10	174	680	
4316/M12S	-	-	-	12	158	640	
4316/4	4216/4	1/2"	-	-	183	740	
4316/4S	4216/4S	-	1/2"	-	166	640	
4316/5	4216/5	5/8"	-	-	245	1380	
4316/5S	4216/5S	-	5/8"	16	230	1240	
4330/3	4230/3	3/8"	-	-	253	1360	
4330/3S	4230/3S	-	3/8"	-	237	1280	
4330/4	4230/4	1/2"	-	-	262	1480	
4330/4S	4230/4S	-	1/2"	-	245	1370	
4330/5	4230/5	5/8"	-	-	187	1300	
4330/5S	4230/5S	-	5/8"	16	173	1200	
4332/4	4232/4	1/2"	-	-	196	1320	
4332/4S	4232/4S	-	1/2"	-	179	1250	
4332/5	4232/5	5/8"	-	-	231	1580	
4332/5S	4232/5S	-	5/8"	16	214	1470	
4341/5	4241/5	5/8"	-	-	232	1640	
4341/5S	4241/5S	-	5/8"	16	219	1560	
4341/6	4241/6	3/4"	-	-	332	2540	
4341/6S	4241/6S	-	3/4"	-	332	2640	
4341/7S	4241/7S	-	7/8"	-	332	2820	
4375/4S	4275/4S	-	1/2"	-	338	2900	
4375/5S	4275/5S	-	5/8"	16	338	3050	
4375/6S	4275/6S	-	3/4"	-			
4375/7S	4275/7S	-	7/8"	-			
4375/9S	4275/9S	-	1.1/8"	-			

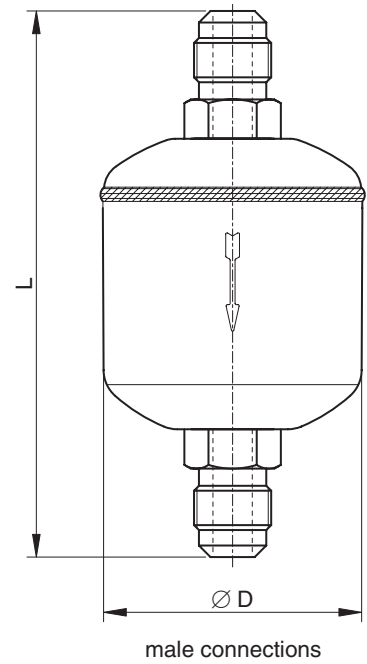

male connections

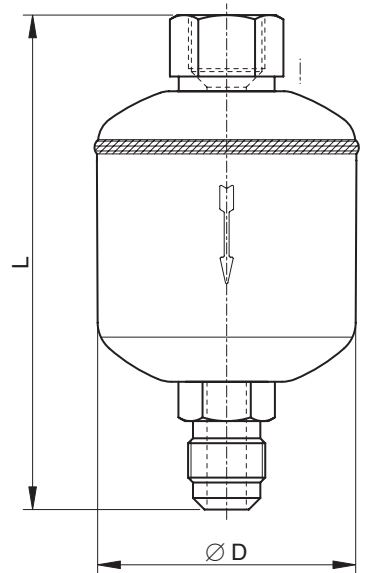

male - female connections (female - in)

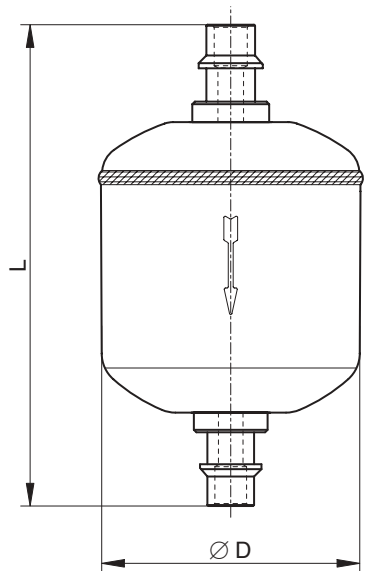

solder connections



FILTER DRIERS WITH REPLACEABLE ANTI-ACID SOLID CORE

Approved by Underwriters Laboratories Inc. (UL)

Except filters 4423/17A, /21A, /25A and 4424/25A, /33A

APPLICATIONS

The filters, shown in this chapter, are classified “Pressure vessels” in the sense of the Pressure Equipment Directive 97/23/EC, Article 1, Section 2.1.1 and are subject of Article 3, Section 1.1 of the same Directive. They are designed for installation on commercial refrigerating systems and on civil and industrial conditioning plants, which use refrigerant fluids proper to the Group II (as defined in Article 9, Section 2.2 of Directive 97/23/EC and referred to in Directive 67/548/EEC).

OPERATION

In the case of filters with more than one block, the passage of the fluid takes place in parallel; as a result, the pressure drop does not increase proportionately to the number of blocks. A large ring between the block and the inner surface of the filter permits the accumulation of solid particles, and prevents clogging. Before leaving the

filter, the refrigerant fluid must pass through the mesh sieve on which blocks are mounted. The danger that small particles of dehydrating material being introduced into the system is thus avoided. Furthermore, at filter outlet, a plastic cup, the edge of which closely adheres to the inner surface of the filter, prevents dirt from reaching the outlet connection during normal operation and block change.

CONSTRUCTION

The filters type 4410 are manufactured in steel, with the exception of the connections which are made of EN 12735-1 – Cu-DHP copper tube.

The filters type 4420 are completely manufactured in steel and solder connection, are machined with a steel bar EN 10025 S355JR.

The blocks series 4490 and 4491 has been developed for specific installations on refrigerating systems using HFC refrigerant fluids, particularly R134a, R404A, R407C, R410A ed R507 mixed with polyolester lubricants. In spite of this, the new block may be successfully used also in refrigerating systems using the old CFC or HCFC refrigerant fluids, mixed with mineral lubricants.

The blocks 4490, type A and type B, and the block 4491, type A, are molded from a blend of dehydrating charge, totally made of 3 Å molecular sieves, and a special binding agent in appropriate proportions. The choice of the 3 Å molecular sieves, as sole dehydrating material, gives to the block a superlative capacity of water adsorption also maintaining quite good deacidifying characteristics.

The blocks 4490, type AA and type AB, and the block 4491, type AA, are molded from a blend of dehydrating charge, 80% of 3 Å molecular sieves and 20 % of activated alumina, and a special binding agent in appropriate proportions. The choice of blend, molecular sieves – activated alumina, gives to the block a very high capacity of acid adsorption also maintaining very good dehydrating characteristics.

The presence of a controlled and defined percentage of activated alumina, lower than the maximum value recommended by ASERCOM, keeps unchanged the original concentration of additives in the polyolester lubricant.



TABLE 1: General Characteristics																					
Catalogue Number	Core Cat. Number	Number of Cores	Core Filtering Surface [cm ²]	Nominal Volume		Connections			TS [°C]		PS [bar]	Risk Category according to PED									
				[cu.in.]	[cm ³]	ODS		ODM	min.	max.											
						Ø [in.]	Ø [mm]	Ø [mm]													
4411/5A		1	420	48	800	5/8"	16														
4411/7A						7/8"	22														
4411/9A						1.1/8"	-														
4411/11A						1.3/8"	35														
4411/13A						1.5/8"	-														
4411/M42A						-	42														
4411/17A						2.1/8"	54														
4412/7A						4490/A -	2	840					96	1600	7/8"	22		-40	+80	45 (1)	I
4412/9A						4490/B -									1.1/8"	-					
4412/11A						4490/AA									1.3/8"	35					
4412/M42A	4490/AB	-	42																		
4412/17A		2.1/8"	54																		
4413/11A	3	1260	144	2400	1.3/8"	35															
4413/13A					1.5/8"	-															
4413/M42A					-	42															
4414/13A					1.5/8"	-															
4414/M42A	4	1680	192	3200	-	42						35 (1)									
4414/17A					2.1/8"	54															
4423/17A					2.1/8"	54	60,3														
4423/21A	4491/A	3	1890	300	4800	2.5/8"	-	76,1			32	II									
4423/25A						4491/AA	3.1/8"	80					88,9								
4424/25A							3.1/8"	80					88,9								
4424/33A							4.1/8"	-					114,3								

(1) PS = 470 psig in compliance with the UL approval

The manufacturing process of blocks series 4490 and 4491 gives a considerable compacted ness and stoutness to both the products so that they are resistant to shocks and abrasions.

The blocks series 4490 have a volume of 48 cu.in., equivalent to approx. 800 cm³, and it is used with type 4411, 4412, 4413 and 4414 filters.

The block series 4491 has a volume of 100 cu.in., equivalent to approx. 1600 cm³, and it is used with type 4421, 4423 and 4424 filters.

The two blocks are shaped as a hollow cylinder and their overall dimensions correspond to those of other international brands. Consequently they are interchangeable. The hollow cylinder shape offers a large surface area to the inflowing fluid, which crosses the block in radial sense. As a result, dehydration is highly efficient with a minimum loss of charge. Filters may be supplied also with an access fitting kit G9150/R05, to be ordered separately.

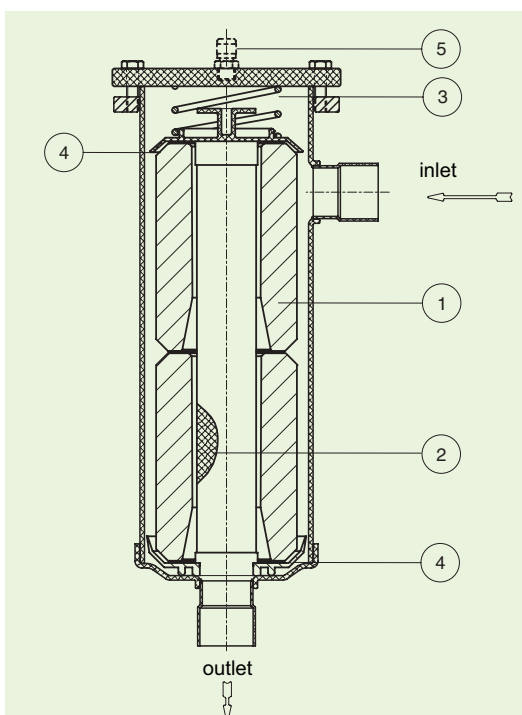

Sketch of filter with 2 blocks

- 1 - Block
- 2 - Mesh sieve serving as block support
- 3 - Spring
- 4 - Retainer cup
- 5 - Access fitting 1/4" SAE flare (to order separately)

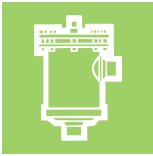

TABLE 2A: Refrigerant Flow Capacity and Water Capacity (filters)

Catalogue Number	Refrigerant Flow Capacity, pressure drop 0,07 bar (1) [kW]					Water Capacity at + 25 °C (2) [g H ₂ O]					Dehydratable Charge at + 25 °C [kg refrigerant]					Water Capacity at + 50 °C (2) [g H ₂ O]					Dehydratable Charge at + 50 °C [kg refrigerant]				
	R134a	R22	R404A	R407C	R410A	R134a	R22	R404A	R407C	R410A	R134a	R22	R404A	R407C	R410A	R134a	R22	R404A	R407C	R410A	R134a	R22	R404A	R407C	R410A
4411/5A	83	90	59	89	90																				
4411/7A	146	158	103	156	159																				
4411/9A	200	216	141	214	217																				
4411/11A	233	252	164	250	253	84	77	86	69	75	90	83	92	74	81	72	61	80	56	60	77	66	86	60	65
4411/13A																									
4411/M42A	250	270	176	268	271																				
4411/17A																									
4412/7A	146	158	103	156	159																				
4412/9A	226	244	159	242	245																				
4412/11A	306	331	215	328	332	168	154	172	138	150	181	166	185	148	161	144	122	160	112	120	155	131	172	120	129
4412/M42A	333	361	234	357	362																				
4412/17A																									
4413/11A	327	354	230	351	355																				
4413/13A	361	391	254	387	393	252	231	258	207	225	271	248	277	223	242	216	183	240	168	180	232	197	258	181	194
4413/M42A																									
4414/13A																									
4414/M42A	426	460	300	456	462	336	308	344	276	300	361	331	370	297	323	288	244	320	224	240	310	262	344	241	258
4414/17A																									
4423/17A	447	483	315	479	485																				
4423/21A	492	532	346	527	534	504	462	516	414	450	542	497	555	445	484	432	366	480	336	360	465	394	516	361	387
4423/25A	670	725	472	719	728																				
4424/25A	737	797	519	791	800																				
4424/33A	1180	1276	830	1265	1281	672	616	688	552	600	723	662	740	594	645	576	488	640	448	480	619	525	688	482	516

TABLE 2B: Refrigerant Flow Capacity and Water Capacity (single block)

Catalogue Number	Refrigerant Flow Capacity, pressure drop 0,07 bar (1) [kW]					Water Capacity at + 25 °C (2) [g H ₂ O]					Dehydratable Charge at + 25 °C [kg refrigerant]					Water Capacity at + 50 °C (2) [g H ₂ O]					Dehydratable Charge at + 50 °C [kg refrigerant]				
	R134a	R22	R404A	R407C	R410A	R134a	R22	R404A	R407C	R410A	R134a	R22	R404A	R407C	R410A	R134a	R22	R404A	R407C	R410A	R134a	R22	R404A	R407C	R410A
4490/A - 4490/B						84	77	86	69	75	90	83	92	74	81	72	61	80	56	60	77	66	86	60	65
4491/A			-			168	154	172	138	150	181	166	185	148	161	144	122	160	112	120	155	131	12	120	129
4490/AA - 4490/AB						71	65	73	59	64	77	70	79	63	69	61	52	68	48	51	66	56	73	51	55
4491/AA			(3)			143	131	146	117	128	154	141	157	126	137	122	104	136	95	102	132	112	146	102	110

(1) Maximum values of the refrigerant flow capacity at which the drier can be used when fluid dehydration is not the a major problem, provided that the original moisture is limited before the installation of the drier. The maximum refrigerant flow capacities are referred to a total pressure drop of 0,07 bar, inlet and outlet connections included, (according to ARI STANDARD 710:86 - with condensing temperature at + 30 °C and evaporating temperature at -15 °C)

(2) Water capacity values with R22 are referred to the following conditions, fixed in ARI STANDARD 710:86:

- Liquid temperatures: 25 °C and 50 °C
- Equilibrium point dryness, EPD: 60 ppm

Water capacity values with the other refrigerant fluids are referred to the following conditions, fixed in DIN 8949:2000 Standard:

- Liquid temperatures: 25 °C and 50 °C
- Equilibrium point dryness, EPD: 50 ppm

(3) Maximum values of the refrigerant flow capacity (according to ARI STANDARD 710:86) at which filter driers:

- series 4411, 4412, 4413, and 4414 can be used with blocks type 4490/AA and 4490/AB
- series 4423 and 4424 can be used with blocks type 4491/AA

when fluid dehydration is not the a major problem, are the same achieved with block type 4490/A, 4490/B and 4491/A.

TABLE 3: Dimensions and Weights

Catalogue Number	Connections		Dimensions [mm]						Weight [g]	
	ODS		W	Ø D ₁	Ø D ₂	H ₁	H ₂	H ₃		P
	Ø [in.]	Ø [mm]								
4411/5A	5/8"	16				148	235		90	5360
4411/7A	7/8"	22				154	241		96	5405
4411/9A	1.1/8"	-				159	246	185	101	5464
4411/11A	1.3/8"	35				171	258		113	5435
4411/13A	1.5/8"	-				162	249		103	5585
4411/M42A	-	42				296	383		96	6880
4411/17A	2.1/8"	54				300	387		101	7015
4412/7A	7/8"	22				312	399		113	6985
4412/9A	1.1/8"	-				303	390		103	7136
4412/11A	1.3/8"	35	-	121	149	442	529	324	101	8510
4412/M42A	-	42				454	541		113	8470
4412/17A	2.1/8"	54				595	682		103	8445
4413/11A	1.3/8"	35				586	673		103	9940
4413/13A	1.5/8"	-				520	641	600	143	10010
4413/M42A	-	42				525	646		148	18000
4414/13A	1.5/8"	-				693	814	760	148	18200
4414/M42A	-	42								18400
4414/17A	2.1/8"	54								21600
4423/17A	2.1/8"	54	60,3							22000
4423/21A	2.5/8"	-	76,1							
4423/25A	3.1/8"	80	88,9	163	200					
4424/25A	3.1/8"	80	88,9							
4424/33A	4.1/8"	-	114,3							

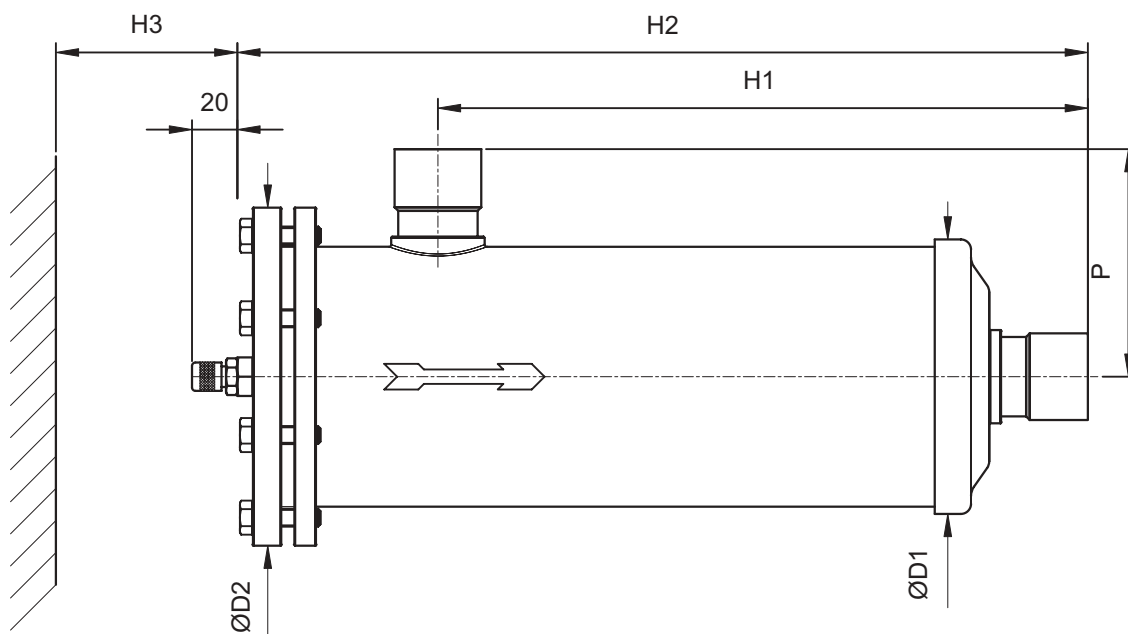



BLOCKS REPLACEMENT

Blocks must be ordered separately from the filter. They are supplied in individual packages, which are hermetically sealed in suitable wrappings (type 4490), and in special bags (type 4491) for safe storage over long periods of time.

Every cartridge is equipped of two seals in synthetic material to use like seal between the two cartridges and between the cartridge and its covers.

If the filter is installed in a system without any by-pass, the block replacement has to be done following these instructions:

- 1 Close the valve on the departing line.
- 2 Start the compressor and its auxiliaries in order to transfer the refrigerant charge into the high pressure side of the plant (liquid receiver).
- 3 Stop the compressor at a suction pressure sufficiently higher than the atmospheric pressure.
- 4 Shutt off the service valve at the suction side of the compressor.

NOTE: if during the transfer of the refrigerant to the high-pressure side of the plant, the discharge pressures reach too high values (the condenser is flooded due to insufficient capacity of the liquid receiver), shut off the valve on the compressor suction side and stop immediately the compressor.

- 5 Replace quickly the filter block. During the preparation of the new block, close the filter with a clean cloth. The slight over-pressure inside the filter and the ability of the technician will prevent air from getting into the plant.

- 6 The internal cleanliness of the body is guaranteed by the cleaning effect of the cup which is characteristic of Castel filters.
if air is supposed to have entered the plant during filter block replacement, produce a vacuum in the low-pressure side of the plant, and always in the sector of the circuit involved.
- 7 Open the valve on the departure of liquid line
- 8 Slowly open the suction valve of the compressor and start the compressor and its auxiliaries.
- 9 Top the charge up, if necessary.

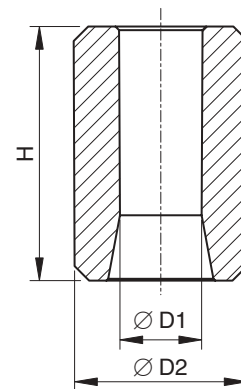

4490

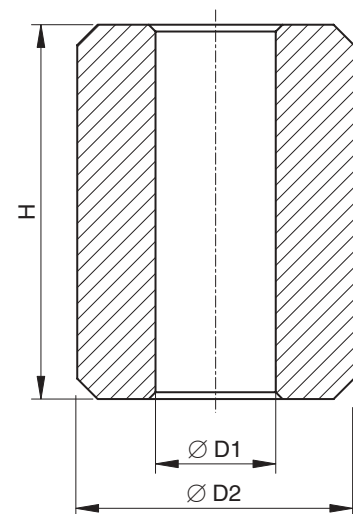

4491

TABLE 4: General Characteristics, Dimensions and Weights

Catalogue Number	Core Filtering Surface [cm ²]	Nominal Volume		Dimensions [mm]			Weight [g]
		[cu.in]	[cm ³]	Ø D ₁	Ø D ₂	H	
4490/A	420	48	800	47	96	140	670
4490/B (1)							
4490/AA							
4490/AB (1)							
4491/A	630	100	1600	53	122	165	1350
4491/AA							

(1) Supplied without cover gasket as spare part

MECHANICAL FILTERS WITH REPLACEABLE FILTERING BLOCK

Approved by Underwriters Laboratories Inc. (UL)

Except filters 4421/21C, /25C, /M80C, /33C

APPLICATIONS

The filters, shown in this chapter, are classified "Pressure vessels" in the sense of the Pressure Equipment Directive 97/23/EC, Article 1, Section 2.1.1 and are subject of Article 3, Section 1.1 of the same Directive. They are designed for installation on commercial refrigerating systems and on civil and industrial conditioning plants, which use refrigerant fluids proper to the Group II (as defined in Article 9, Section 2.2 of Directive 97/23/EC and referred to in Directive 67/548/EEC).

OPERATION

Good filtering of the refrigerant on the low-pressure side of the system is a guarantee of protection for the compressor. System cleanliness is ensured by micro filtering cores, which filter out impurities derived from manufacture and assembly of the refrigerating system.

CONSTRUCTION

The filters type 4410 are manufactured in steel, with the exception of the connections which are made of EN 12735-1 – Cu-DHP copper tube.

The filters type 4420 are completely manufactured in steel and solder connection, are machined with a steel bar EN 10025 S355JR.

Zinc plated wire cloths and a filtering baffle form the block, which features a large surface, with controlled porosity. The block can stop solid particles up to 20 micron. At the two ends, soft € felt gaskets ensure perfect sealing with the plastic cups. Filters are supplied with an access fitting kit G9150/R05.

SUCTION LINE

SELECTION CRITERION

With clean systems, refrigerant flow capacity and pressure drops of table 2 are reported to a gas speed of 20 m/s for pipes adequate to the filter connections.

For refrigerant flow capacities different from the table values, under the other same conditions, gas speeds and relative pressure drops through the filter can be gained for simple proportionality.

EXAMPLE

System data:

Refrigerant: R407C

Refrigerant flow capacity: 130 [kW]

Evaporating temperature: + 5 [°C]

Suction pipe: Ø 2.1/8"

Filter: 4411/17C

In table 2, corresponding to filter type 4411/17C refrigerant and evaporating temperature, the following data is given:

- refrigerant flow capacity = 141,7 [kW];
- pressure drop = 0,21 [bar].

The gas speed in the suction line will be:

$$20 \times \frac{130^2}{141,7^2} = 16,8 \text{ [m/s]}$$

Pressure drop through the filter:

$$0,21 \times \frac{130^2}{141,7^2} = 0,177 \text{ [bar]}$$

Remember that the dimensioning of the suction line in a refrigerating system requires great attention.

In fact the relative pressure loss, included filter, which implies a reduction of flow capacity sucked by the compressor, influences directly the refrigerating capacity of the plant.

This line is normally sized to have a total pressure loss lower than a variation of the saturation temperature of 1° C.

For example diagram 1, referred to R22, allows to estimate the aforesaid variation in function of pressure loss and evaporating temperature.



After all it's always important to remember that the refrigerant flow capacity of a compressor, under the other same conditions, can reduce considerably because of the decrease of the saturation temperature, consequent to the pressure loss in the suction line.

To such purpose diagram 2 illustrates the existing relation between saturation temperature, in the suction line, and variation of the refrigerant flow capacity of a compressor.

TABLE 1: General Characteristics										
Catalogue Number	Core Cat. Number	Number of Cores	Core Filtering Surface [cm ²]	Connections			TS [°C]		PS [bar]	Risk Category according to PED
				ODS		W	min.	max.		
				Ø [in.]	Ø [mm]	Ø [mm]				
4411/7C	4495/C	1	820	7/8"	22	-	- 40	+80	45 (1)	I
4411/9C				1.1/8"	-					
4411/11C				1.3/8"	35					
4411/13C				1.5/8"	-					
4411/M42C				-	42					
4411/17C				2.1/8"	54					
4411/21C	4496/C	1	1850	2.5/8"	-	76,1	- 40	+80	32	I
4421/21C				2.5/8"	-					
4421/25C				3.1/8"	80					
4421/33C				4.1/8"	-					

(1) PS = 470 psig in compliance with the UL approval

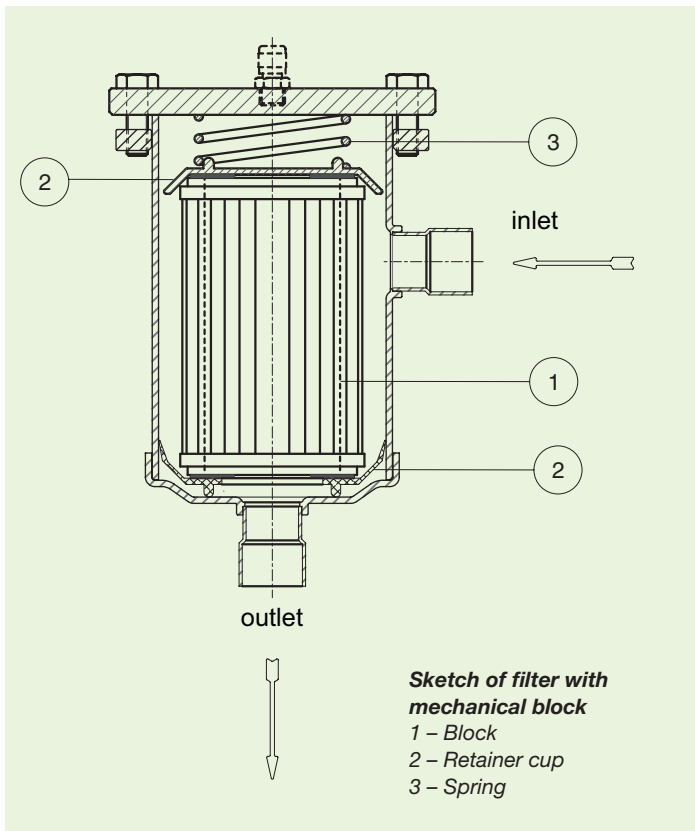

DIAGRAM 1

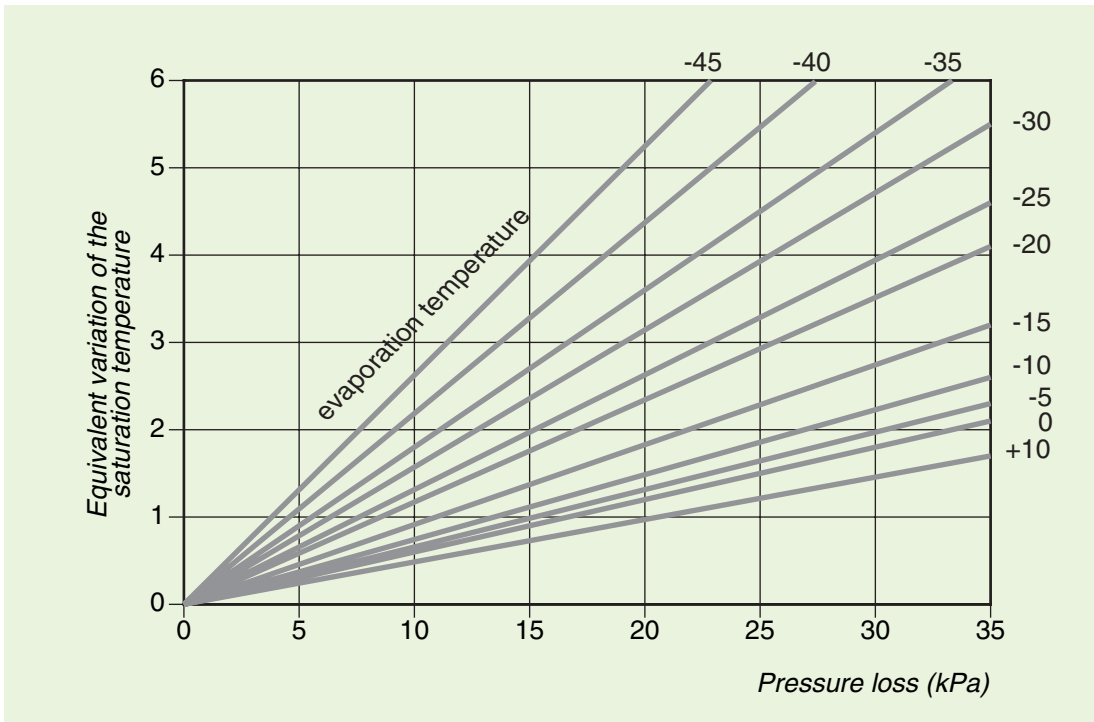

DIAGRAM 2

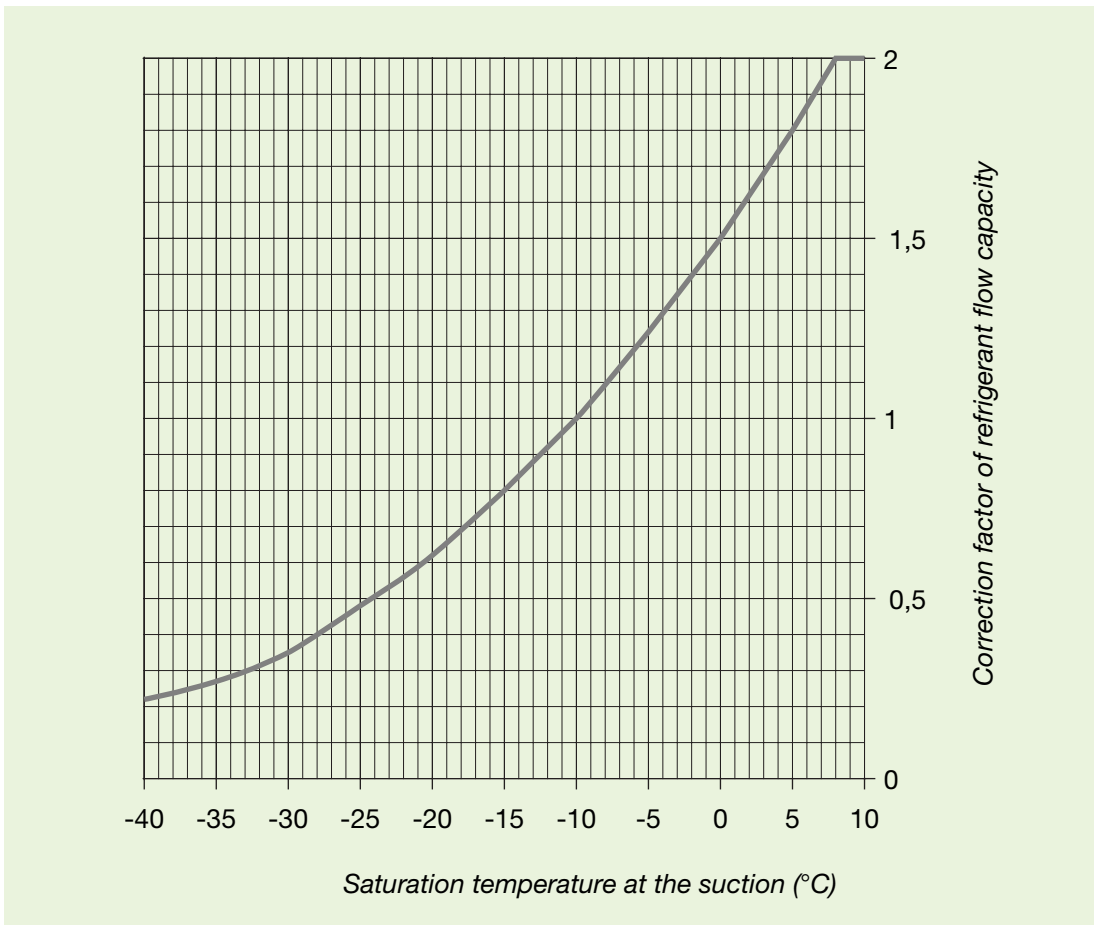



TABLE 2: Refrigerant Flow Capacity and Pressure Drop

Catalogue Number	Refrigerant	Evaporating Temperature [°C]									
		+5		0		-10		-20		-30	
		[kW]	[bar]	[kW]	[bar]	[kW]	[bar]	[kW]	[bar]	[kW]	[bar]
4411/7C	R134a	17,0	0,084	13,7	0,070	9,0	0,048	6,0	0,033	3,5	0,021
	R22	26,0	0,120	21,5	0,100	15,6	0,074	10,8	0,052	7,2	0,037
	R404A	23,7	0,150	20,0	0,130	14,0	0,090	9,0	0,060	6,0	0,040
	R407C	22,2	0,100	19,0	0,090	12,8	0,060	8,4	0,043	5,1	0,028
	R410A	38,4	0,230	31,7	0,200	23,0	0,140	16,0	0,100	10,6	0,100
4411/9C	R134a	28,7	0,091	23,0	0,074	15,0	0,051	10,0	0,035	6,0	0,022
	R22	43,0	0,130	36,4	0,110	26,0	0,080	18,0	0,056	12,0	0,040
	R404A	40,0	0,160	34,0	0,140	24,0	0,100	15,0	0,070	10,0	0,050
	R407C	37,6	0,110	32,1	0,100	21,3	0,066	14,2	0,047	8,7	0,031
	R410A	63,5	0,250	53,7	0,210	38,0	0,150	26,0	0,110	17,7	0,110
4411/11C	R134a	43,5	0,092	35,0	0,075	23,0	0,052	15,0	0,036	9,0	0,023
	R22	65,0	0,130	55,0	0,110	39,0	0,080	27,0	0,056	18,0	0,040
	R404A	60,7	0,160	51,4	0,140	36,2	0,100	22,7	0,070	14,5	0,050
	R407C	57,0	0,110	48,6	0,100	33,2	0,068	21,9	0,047	13,4	0,031
	R410A	96,0	0,250	81,0	0,210	57,0	0,150	40,0	0,110	26,0	0,110
4411/13C 4411/M42C	R134a	62,0	0,110	50,0	0,090	33,0	0,062	21,4	0,043	13,0	0,027
	R22	93,0	0,150	79,0	0,130	56,0	0,090	39,0	0,064	26,0	0,046
	R404A	86,8	0,200	73,5	0,170	51,7	0,120	32,4	0,080	20,7	0,060
	R407C	81,4	0,136	69,5	0,120	47,5	0,080	31,3	0,056	19,2	0,037
	R410A	137,0	0,300	116,0	0,250	82,0	0,180	57,0	0,120	38,0	0,100
4411/17C	R134a	108,3	0,170	87,0	0,140	57,2	0,100	37,3	0,070	22,4	0,040
	R22	162,0	0,230	137,0	0,190	97,0	0,150	66,4	0,100	44,0	0,070
	R404A	151,3	0,310	128,0	0,270	90,0	0,190	56,5	0,130	36,0	0,100
	R407C	141,7	0,210	121,1	0,180	82,6	0,125	54,4	0,087	33,4	0,057
	R410A	239,0	0,440	202,0	0,370	143,0	0,290	98,0	0,250	65,0	0,200
4411/21C	R134a	167,0	0,300	133,5	0,250	87,5	0,180	57,0	0,120	34,3	0,070
	R22	249,0	0,420	211,0	0,360	149,0	0,270	102,0	0,180	68,0	0,120
	R404A	232,7	0,550	197,0	0,480	138,6	0,330	87,0	0,230	55,5	0,170
	R407C	218,0	0,380	186,4	0,330	127,0	0,210	83,7	0,150	51,4	0,100
	R410A	368,0	0,810	311,0	0,700	220,0	0,520	150,0	0,350	100,0	0,240
4421/21C	R134a	167,0	0,120	133,5	0,100	87,5	0,070	57,0	0,050	34,3	0,030
	R22	249,0	0,170	211,0	0,150	149,0	0,110	102,0	0,074	68,0	0,050
	R404A	232,7	0,220	197,0	0,200	138,6	0,130	87,0	0,100	55,5	0,070
	R407C	218,0	0,160	186,4	0,140	127,0	0,090	83,7	0,060	51,4	0,040
	R410A	368,0	0,340	311,0	0,300	220,0	0,200	150,0	0,150	100,0	0,100
4421/25C	R134a	238,0	0,210	191,0	0,180	125,0	0,120	81,5	0,090	49,0	0,050
	R22	356,0	0,300	302,0	0,260	213,0	0,190	146,0	0,130	97,0	0,090
	R404A	332,0	0,390	281,0	0,340	198,0	0,220	124,0	0,170	79,3	0,120
	R407C	312,0	0,270	266,0	0,230	182,0	0,150	119,7	0,100	73,5	0,070
	R410A	526,0	0,600	446,0	0,500	315,0	0,370	215,0	0,250	143,0	0,200
4421/33C	R134a	416,0	0,630	334,0	0,540	218,0	0,360	142,0	0,270	85,0	0,150
	R22	623,0	0,900	528,0	0,770	372,0	0,570	255,0	0,390	170,0	0,270
	R404A	581,0	1,170	491,0	1,000	346,0	0,660	217,0	0,500	138,7	0,360
	R407C	547,0	0,790	468,0	0,690	320,0	0,440	210,0	0,300	129,0	0,200
	R410A	921,0	1,800	780,0	1,400	550,0	1,200	377,0	0,800	251,0	0,530

Refrigerant flow capacities and pressure drops are referred to the following working conditions:

- Liquid temperature ahead expansion valve: + 35 °C
- Overheating of suction gas: 6 °C

TABLE 3: Dimensions and Weights

Catalogue Number	Connections			Dimensions [mm]						Weight [g]
	ODS		W	Ø D ₁	Ø D ₂	H ₁	H ₂	H ₃	P	
	Ø [in.]	Ø [mm]	Ø [mm]							
4411/7C	7/8"	22				154	241		96	5450
4411/9C	1.1/8"	-								5375
4411/11C	1.3/8"	35				159	246		101	5435
4411/13C	1.5/8"	-	-	121	149	171	258	185	113	5410
4411/M42C	-	42				162	249		103	5585
4411/17C	2.1/8"	54				186	273		128	6030
4411/21C	2.5/8"	-				187	308		143	12000
4421/21C	2.5/8"	-	76,1			192	313	200	148	12200
4421/25C	3.1/8"	80	88,9	163	200					12200
4421/33C	4.1/8"	-	114,3							12500

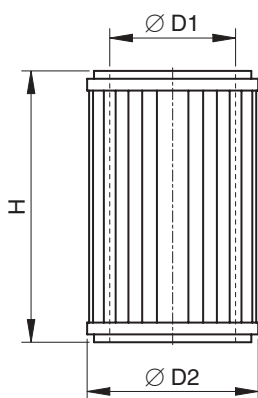

4495 - 4496

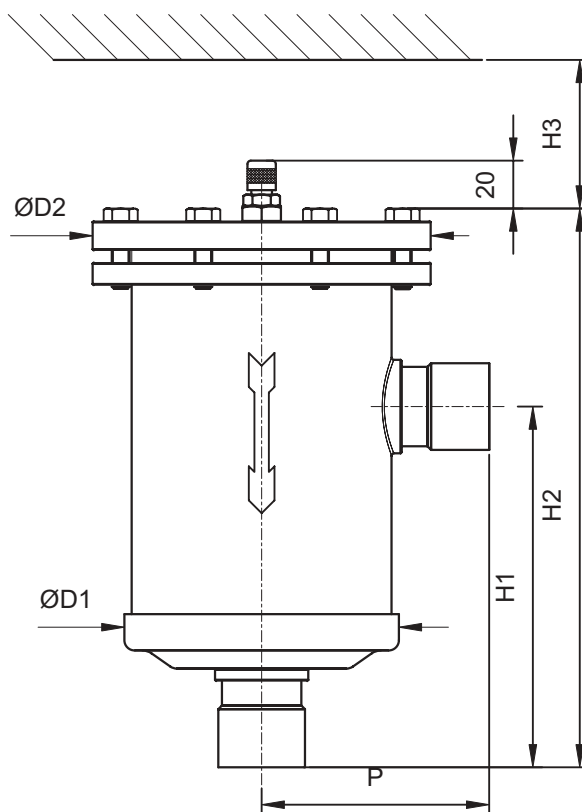

TABLE 4: General Characteristics Dimensions and Weights

Catalogue Number	Filtering Surface		Dimensions [mm]			Weight [g]
	[sq.in]	[cm ²]	Ø D ₁	Ø D ₂	H	
4495/C	127	820	60	87	138	480
4496/C	287	1850	80	113	168	750



STRAINERS

APPLICATIONS

The filters, shown in this chapter, are classified “Pressure vessels” in the sense of the Pressure Equipment Directive 97/23/EC, Article 1, Section 2.1.1 and are subject of Article 3, Section 1.1 of the same Directive. They are designed for installation on commercial refrigerating systems and on civil and industrial conditioning plants, which use refrigerant fluids proper to the Group II (as defined in Article 9, Section 2.2 of Directive 97/23/EC and referred to in Directive 67/548/EEC).

CONSTRUCTION

The filter is completely manufactured in steel, either with nickel-plated Flare threaded connections. The product range also includes types with copper plated solder connections, offering the possibility to solder the copper pipe inside the connections (ODS) or outside the connections (ODM), using a copper sleeve (ODM). Inside the filters there is a screen basket, with wide filtering surface, made of austenitic stainless steel AISI 304. These filters may not be cleaned.

TABLE 1: General Characteristics

Catalogue Number	Filtering Surface [cm ²]	Useful Passage Surface [%]	Mesh Opening [mm]	Connections				Kv Factor [m ³ /h]	TS [°C]		PS [bar]	Risk Category according to PED	
				SAE Flare	ODS		ODM		min.	max.			
					Ø [in.]	Ø [mm]	Ø [in.]						Ø [mm]
4510/3	58	36,6	0,166	3/8"	-	-	-	-	- 40	+80	42	Art. 3.3	
4510/4	142			1/2"	-	-	-	-					
4520/3	58			-	3/8"	-	1/2"	-					2,4
4520/M10				-	-	10	-	12					2,4
4520/M12				-	-	12	-	14					3,4
4520/4				-	1/2"	-	5/8"	16					3,4
4520/5				-	5/8"	16	3/4"	-					8,0
4520/M18	142			-	-	18	-	22					8,0

TABLE 2: Dimensions and Weights

Catalogue Number	Dimensions [mm]		Weight [g]
	Ø D	L	
4510/3	52	110	195
4510/4	76	174	515
4520/3	52	109	195
4520/M10		113	205
4520/M12		122	215
4520/4		126	245
4520/5		170	495

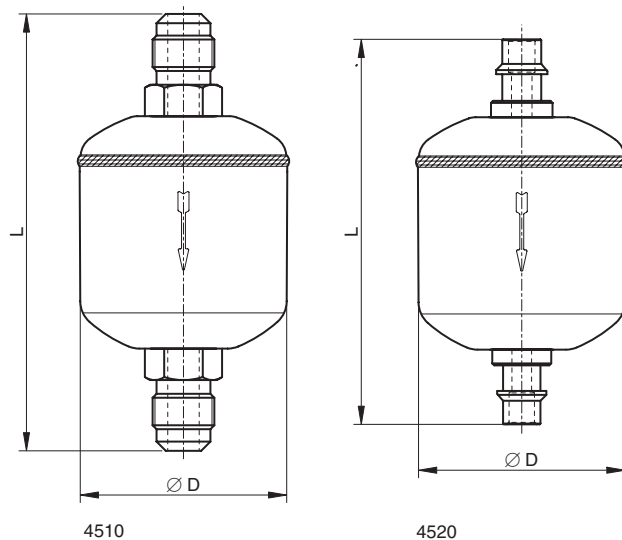

DESSICCANTS

For using on refrigerating systems, Castel puts the following desiccants at disposal of its own customers:

- Activated alumina Code No 4901/AA
- Molecular sieve Code No 4901/MS
- Silicagel Code No 4901/SG

hermetically sealed in steel cans with a weight of about 0,750 kg and supplied in multiply package of 15 cans.